

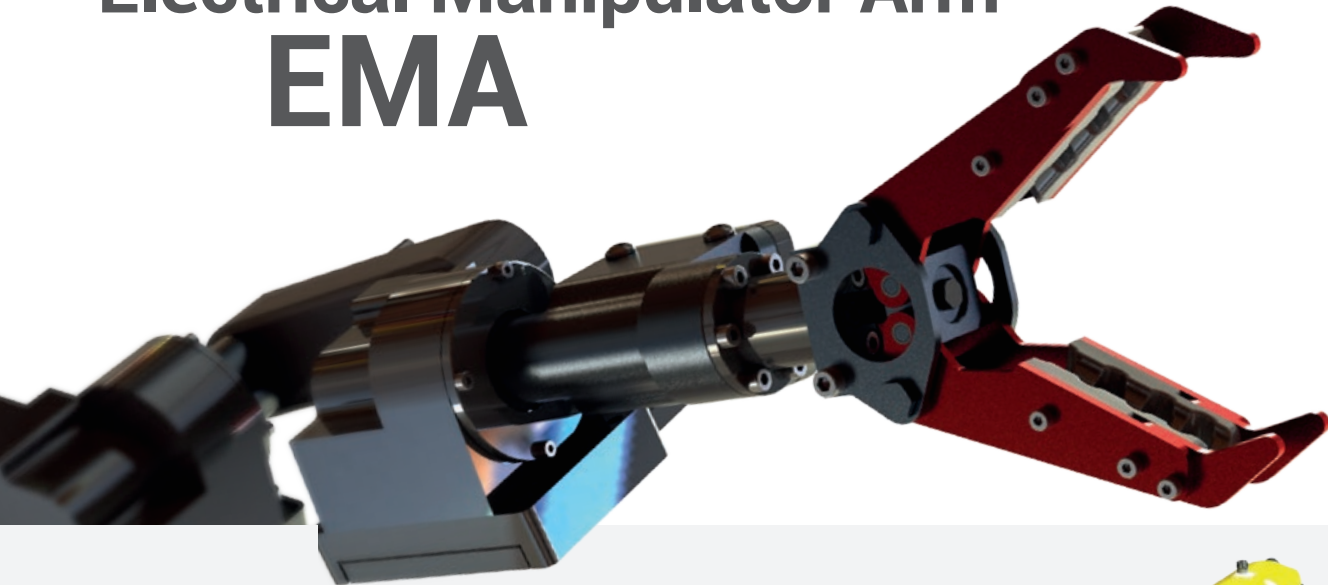

Electrical Manipulator Arm EMA



Compatible with:



ROV Tortuga
(XS and XL)

The manipulator arm EMA designed by Subsea Tech, is based on a modular concept leading to a highly customisable tool.

Thanks to its movable serial actuators, the arm can have up to 7 functions. Moreover, the heads are also interchangeable and the standard manipulator can be replaced with a large range of tools: parallel pliers, cutter, grabber, sampler, etc.

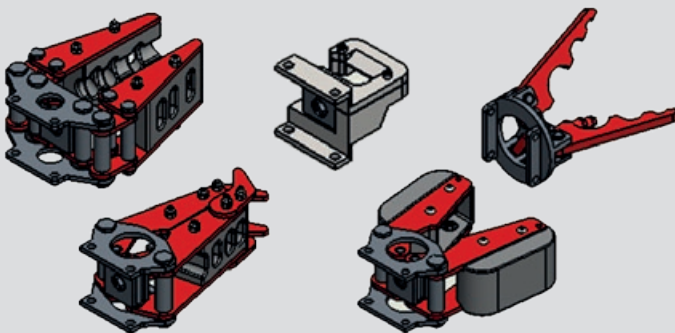

EMA - 3 functions

Weight in air/water	5.2kg / 1.9kg
Dimensions L x W x h	650mm x 260mm x 110mm
Max. torque	100 N.m
Max. pliers force	90 N
Control	Max. torque, direction, RPM
Outputs	% tool aperture/jaws opening, revolution counter, angular position



www.subsea-tech.com



+33 (0) 491 517 671



SubseaTech_



st.sales@subsea-tech.com



SubseaTech



subsea-tech